

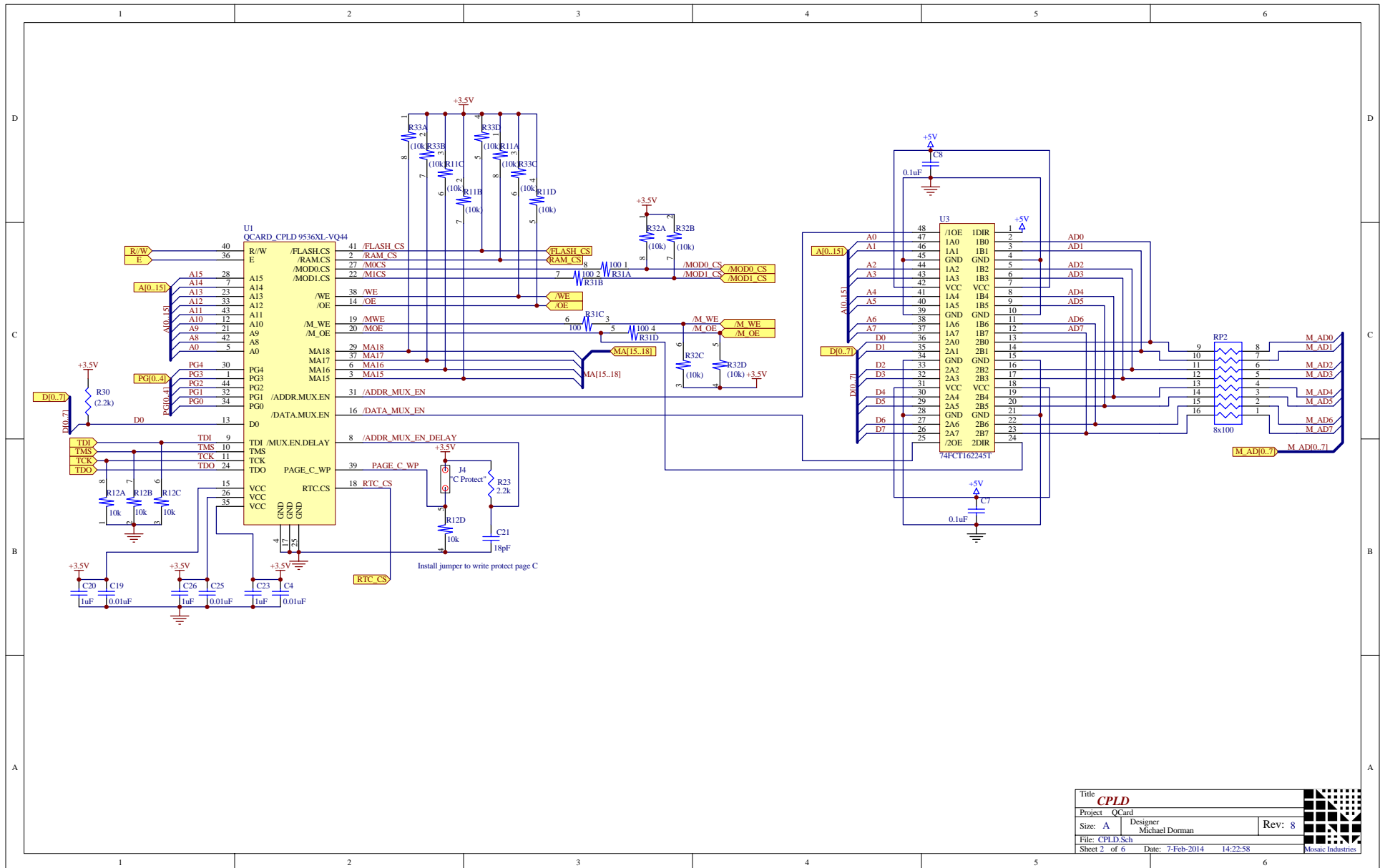

Title Processor		
Project	QCard	
Size: A	Designer Michael Dorman	Rev: 8
File: Processor.Sch		
Sheet 1 of 6	Date: 7-Feb-2014	14:21:47
		Mosaic Industries

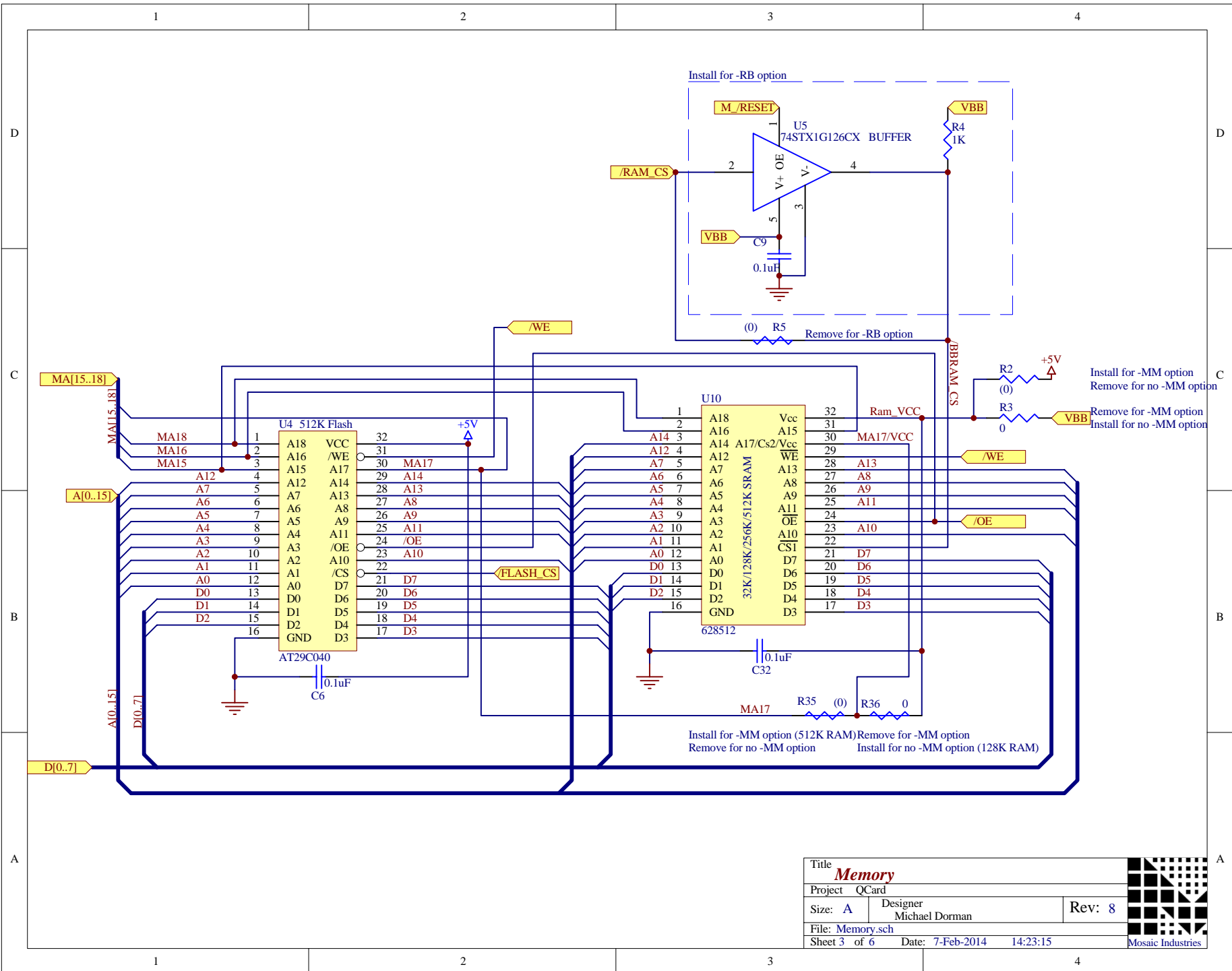



Title		
Project QCard		
Size: A	Designer Michael Dorman	Rev: 8
File: Memory.sch		
Sheet 3 of 6	Date: 7-Feb-2014	14:23:15

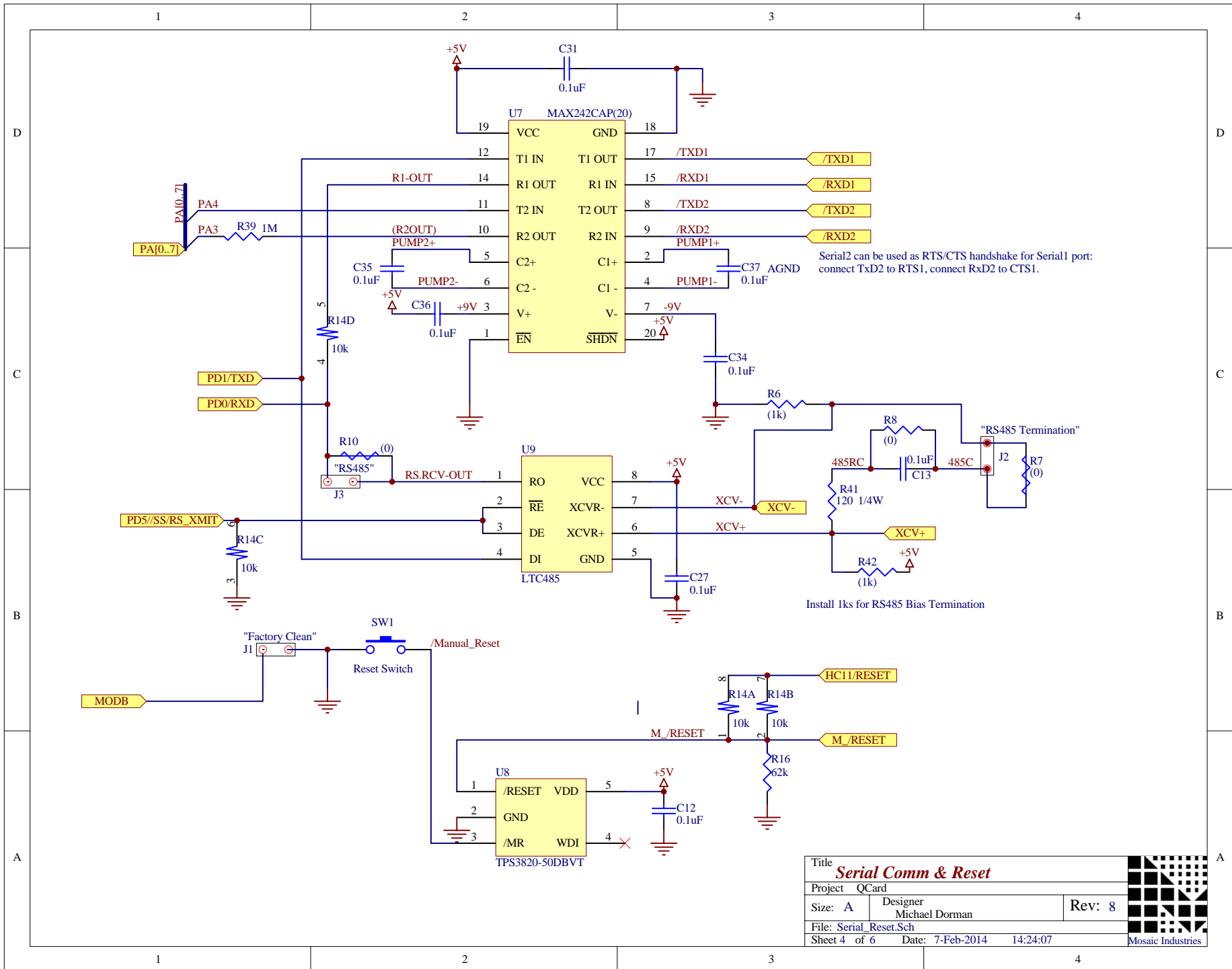

Title Serial Comm & Reset		
Project QCard		
Size: A	Designer Michael Dorman	Rev: 8
File: Serial_Reset.Sch		
Sheet 4 of 6	Date: 7-Feb-2014	14:24:07
Mosaic Industries		

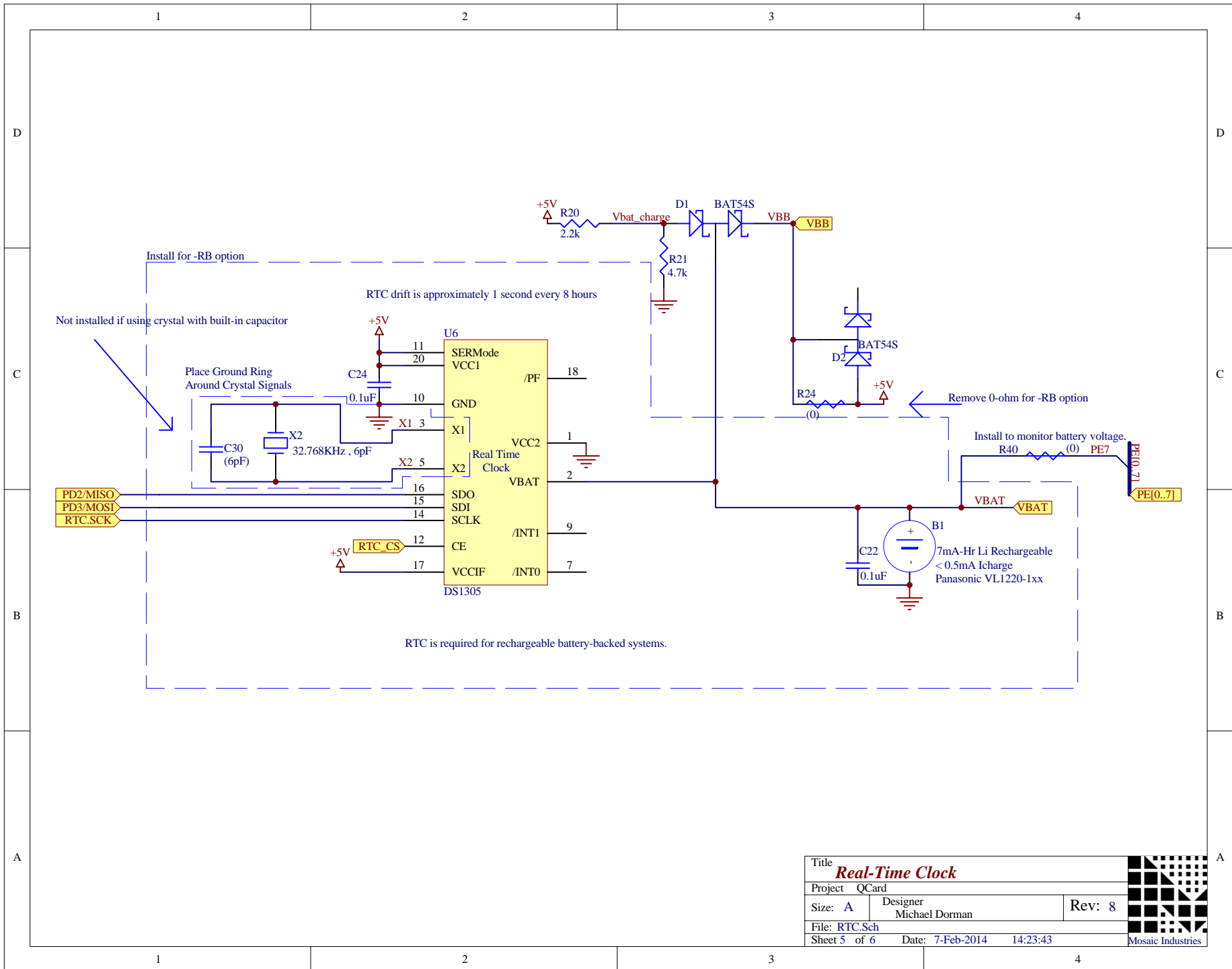

Title			
Project			
Size: A	Designer Michael Dorman		Rev: 8
File: RTC.Sch			
Sheet 5 of 6	Date: 7-Feb-2014 14:23:43		

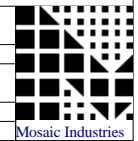

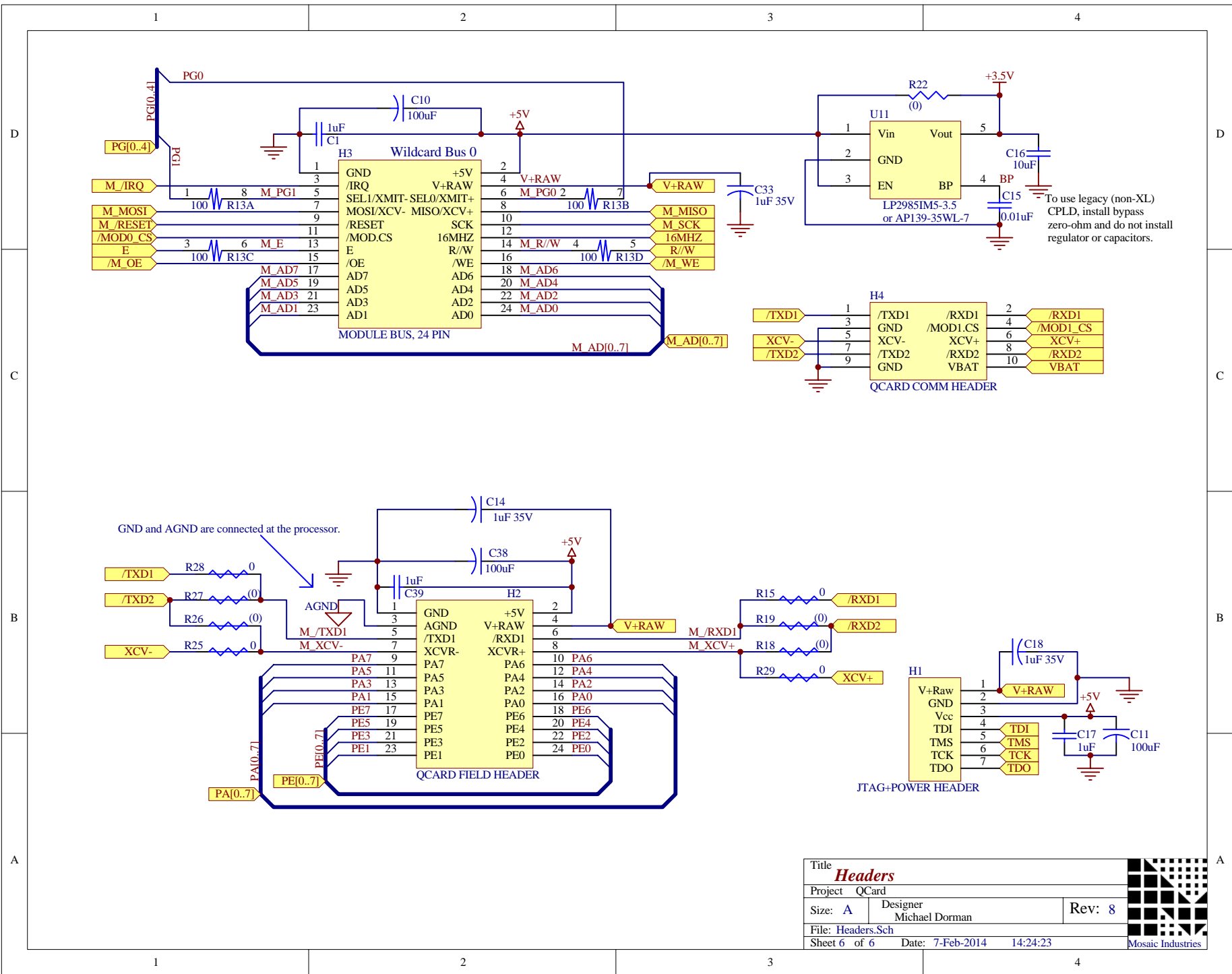

Title		Headers	
Project		QCard	
Size: A	Designer	Michael Dorman	Rev: 8
File: Headers.Sch			
Sheet 6 of 6	Date: 7-Feb-2014	14:24:23	

