

All resistors and jumpers are typically not installed. You can install through-hole resistors, capacitors, and diodes in the footprints of the jumpers for a wide range of pull up, pull down, resistor divider, high pass, low pass, and clamping options.

Title: Filters		
Project: I/O Filter Wildcard	Designer: Paul Clifford	Rev: 1
File: Filters.sch	Date: 30-Nov-2015	11:41:56
Sheet 1 of 2	Mosaic Industries	

D

D

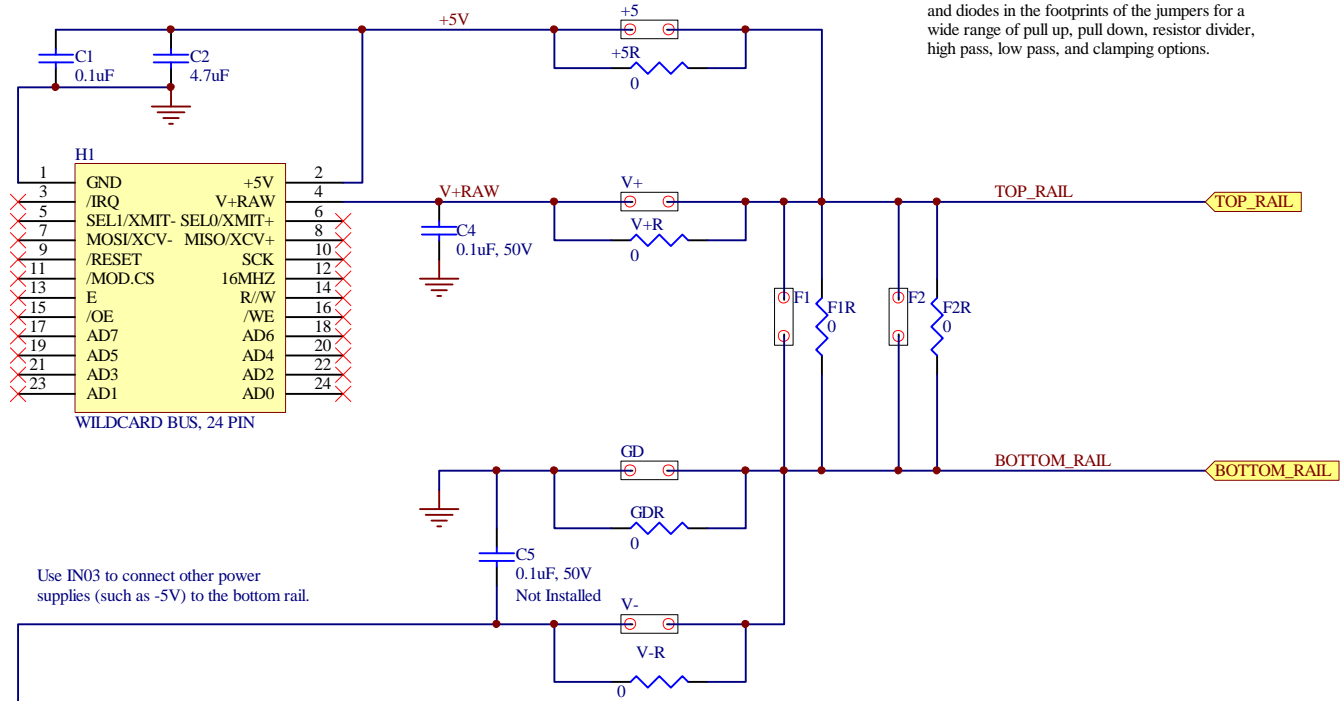

All resistors and jumpers are typically not installed. You can install through-hole resistors, capacitors, and diodes in the footprints of the jumpers for a wide range of pull up, pull down, resistor divider, high pass, low pass, and clamping options.

C

C

Use IN03 to connect other power supplies (such as -5V) to the bottom rail.

B

B

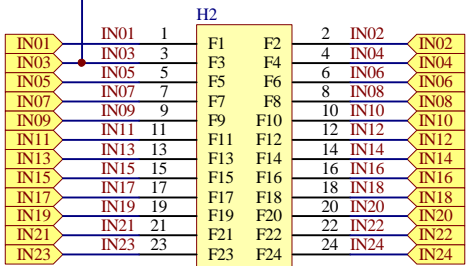

INPUT FIELD HEADER, 24 PIN
(Connects to signals, sensors, or actuator lines)

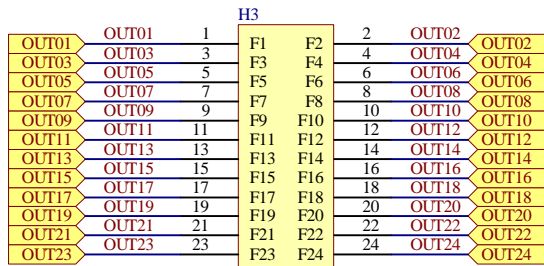

OUTPUT FIELD HEADER, 24 PIN
(Connects to the Field Header of the other Wildcard)

A

A

Title		Headers	
Project	I/O Filter Wildcard		
Size	A	Designer	Paul Clifford
File	Headers.Sch		Rev: 1
Sheet	2 of 2	Date:	30-Nov-2015 11:49:38
			Mosaic Industries